

# ZAXIS190



## HYDRAULIC EXCAVATOR

Model Code : ZX190LC-5B / ZX190LCN-5B

Engine Rated Power : 122 kW (164 HP)

Operating Weight ZX190LC-5B : 19 000 - 20 600 kg

ZX190LCN-5B : 18 700 - 19 900 kg

Backhoe Bucket ISO Heaped : 0.45 - 1.00 m<sup>3</sup>



# WALK AROUND

## CONTENTS

### 4-5 Performance

Enhanced power, torque and speed ensure the optimum performance of every Hitachi machine.

### 6-7 Productivity

The new ZAXIS have a high impact on efficiency but a low impact on the environment.

### 8-9 Comfort

The cab of the new ZAXIS provides a safer and comfortable work space.

### 10-11 Durability

Hitachi is renowned for manufacturing high-quality machines that can meet the demands of the toughest job sites.

### 12-13 Maintenance

Easily accessible features for cleaning and routine maintenance maximise the availability of the ZAXIS 190.

### 14-15 Hitachi Support Chain

A wide range of after-sales services and support options is available to all our customers.

### 16-22 Specifications

#### Higher productivity

The high output engine and the TRIAS hydraulic system achieve higher productivity with better fuel efficiency than similar class models, which helps to reduce costs.

#### Added durability

The strengthened brackets on the boom end and foot are equipped with bushings to withstand rugged environments.

#### Faster movement

The arm recirculation cancel and hydraulic boosting systems increase the arm speed during operation.

#### Enhanced versatility

Two additional spools in the control valve allow for the easy installation of attachments.



**ZAXIS** Empower your Vision.

The design of the new Hitachi ZAXIS 190 medium excavator is inspired by one aim – empower your vision. It delivers on five key levels: performance, productivity, comfort, durability and reliability. We recognise that fleet owners require high-quality, efficient machines that can work effectively, even in challenging conditions. We also realise that operators need a safer, user-friendly work space, and a machine that can respond to their skills with speed and precision. And to achieve a satisfying result, on time, on budget and to a high standard, we have aimed to maximise availability of the new ZAXIS 190 with easy maintenance features and the Hitachi Support Chain after-sales programme.

### **Expanded leg room**

The seat and console can slide further back on the new ZAXIS, providing a more comfortable working environment for the operator. The rightside console has been ergonomically re-designed.

### **Ultimate comfort**

The heated air suspension seat is ideal in cold climates and absorbs vibration during operation minimising operator fatigue.

### **Easily accessible information**

The large multi-function LCD monitor screen is easy to view in bright sunlight or darkness and provides technical data.

### **Quick and easy service access**

The air conditioning condenser can be easily opened for cleaning the condenser and radiator. Inspection parts are conveniently located.





# PERFORMANCE

Faster and more powerful, the new ZAXIS 190 is guaranteed to achieve new levels of performance on any earthmoving or construction site. With a larger engine than similar class models, it will enable you to access the increased power when it matters most, so you can operate the machine more productively, smoothly and precisely than ever before. So you can feel confident that your decision to buy Hitachi will set you apart from the competition.



# Enhanced power and speed set a new standard on the job site



## Lower fuel costs

Winning tenders and meeting production targets are highly competitive processes for you to develop your business. The choice of construction machinery is of paramount importance and your success relies on the productivity and efficiency of your equipment. This is where our new TRIAS hydraulic system comes into its own.

The latest advanced hydraulic and electronic technologies are central to our goal of delivering a significant saving on fuel costs with the new low-emission engine. We are delighted that TRIAS hydraulics allow you to achieve 5% increase in production and 3% better fuel efficiency in PWR mode – than the ZX180-3 P-mode\*.

Furthermore, an increase of 12% in fuel efficiency is also possible in ECO mode\*. This still delivers a relatively high level of productivity using the same amount of fuel.

## Higher level of performance

A powerful, fast and precise machine is every operator's dream – and that's exactly what the ZAXIS 190 offers. Our latest innovations have been developed specifically for the new generation of Hitachi medium excavators.

This ZAXIS 190 has been developed with increased power and higher levels of productivity in mind. We have succeeded in achieving these objectives by introducing a larger engine than similar class models, without compromising on the compact size of the machine.

The hydraulic boosting system and other hydraulic systems enable the arm roll-in speed to increase when the load is relatively low. Our tried-and-tested power-boost feature has also increased by 10%\* (vs ZX180-3) to deliver an enhanced level of excavating performance.

The versatility of the ZAXIS 190 may be evidenced by the attachment support system, with 11 modes that can be registered on the monitor for the easy fitment of different attachments. These two auxiliary spools are useful for attachments that require multiple, large volumes of oil flow.

*\* Based upon typical work pattern collected via Global e-Service*

## Key features

■ 5% increase in production  
(PWR mode vs ZX180-3 P-mode)\*

■ 12% increase in fuel efficiency  
(ECO mode vs ZX180-3 P-mode)\*

■ New TRIAS hydraulic system  
higher productivity and better fuel efficiency

■ Attachment support system

■ Power-boost

■ Two additional spools

■ High output engine

■ High traction force



# PRODUCTIVITY

The new ZAXIS medium excavator range has been created with two important commitments from Hitachi in mind. The first is our commitment to our customers: to manufacture machinery that will enable you to maximise productivity on the job site, so your business can make a profit. The second is our commitment to a sustainable future, by designing machines that contribute to a cleaner, and also quieter, working environment.



# Striking a balance between powerful and sustainable efficiency



## Sustainable efficiency

We are dedicated to the sustainable development of the Hitachi product range, particularly for use on urban job sites. Therefore, the new ZAXIS 190 is a sign of our commitment to minimising the impact of construction machinery on the environment in compliance with EU emission control Stage IIIB.

The ZAXIS 190 has been fitted with a muffler filter to capture air pollutants, which is automatically burnt thanks to an oxidation catalyst and exhaust temperature control. The variable geometry turbocharger and high volume-cooled EGR (Exhaust Gas Recirculation) also help to reduce nitrous oxide levels.

As well as reducing emissions, the ZAXIS 190's Auto Shut-down helps to prevent fuel wastage and lowers the level of noise in the cab.

In addition, all resin parts on the new ZAXIS medium excavator range are suitable for recycling and clearly marked for ease of use in this process.

## Powerful efficiency

We are also focusing on finding the right balance between people, planet and profit. So, we have assessed the total cost of ownership for the new ZAXIS 190 to ensure that your new machine contributes to the profitability of your business.

The powerful new-generation Stage IIIB-compliant engine in the ZAXIS 190 delivers higher productivity, with greater fuel efficiency and is fitted with state-of-the-art controls throughout all of the components. The TRIAS hydraulic system has also been developed to reach higher yields with better fuel consumption than the previous ZAXIS model.

Hitachi medium excavators are renowned for their powerful and reliable performance, especially when there are daily targets and ultimate deadlines to meet on busy job sites. The latest range of ZAXIS models have been designed for increased productivity without burdening the environment through sustainable operations.

## Key features

- Powerful and sustainable
- Stage IIIB-compliant engine
- Muffler filter that captures particulate matter
- Variable geometry turbocharger
- High volume-cooled EGR system
- TRIAS hydraulic system – fuel efficiency and higher productivity
- Environmentally friendly design
- Auto Shut-down – fuel saving for carbon dioxide reduction



# COMFORT

The design of the cab for the new ZAXIS medium excavator range has been designed by experts in the field – owners and operators who know their Hitachi machines inside out. With your invaluable feedback, we have created a cab that is safe and spacious, offers all-round visibility and incorporates a range of user-friendly features. All of these contribute to a comfortable working environment in which you'll enjoy spending time, day after day.





# Inside and out, the new ZAXIS medium excavators lead the way



## From the comfort of the cab

After a long shift on a road construction site or in the quarry, you need to feel ready to enjoy the rest of your day. Hitachi has taken the lead in operator comfort with the new ZAXIS 190, so that you can do just that.

The fully adjustable air-suspension seat features a new sliding mechanism with the capacity to be moved back further than ever before. The space underneath the monitor has also been expanded to allow for more leg room. The pressurized cab keeps dust and particles from entering.

## All-round visibility

Busy construction sites demand your full attention to avoid unnecessary damage or health and safety issues. The enhanced visibility – especially down the right-hand side of the new ZAXIS – will also save you time (and money), thanks to the latest innovations from Hitachi.

The repositioning of the monitor and door enhances your view, as well as making access to and from the cab much easier. The latest rear-view camera offers a closer view of the counterweight to minimise the blind spot.

## User-friendly functionality

Hitachi has invested heavily in the advanced technology inherent within the new ZAXIS. The power remains firmly at your fingertips thanks to the functionality of the colour monitor and ergonomic controls.

The new multi-function LCD monitor has a large seven-inch screen that is easy to view. It provides a wide range of useful technical information, including a clear indication of the machine's status and settings with multi-lingual support in up to 32 languages. The monitor and ergonomically designed switches have been grouped together within easy reach of your right hand. The proportional switch in the new, optional, auxiliary function lever allows easy control of the front attachment.

## Enjoy your work

Time flies when you're having fun, but we also realise that a happy operator is also a more productive one. That's why we have renewed our focus on providing a relaxed and enjoyable working environment within the cab.

The controls for the AM/FM stereo radio are now fully adjustable from the colour monitor. An auxiliary terminal has also been added to the sound system, so that you can work efficiently and smoothly to your favourite music via devices such as MP3 players and the inclusion of storage for an MP3 player.

## Key features

- High-spec ROPS pressurised cab
- Enhanced visibility
- New colour LCD monitor
- Easily accessible real-time information

- Expansive leg room
- Ergonomically designed control panel
- Auxiliary terminal and storage for an MP3 player



# DURABILITY

For more than 40 years, Hitachi has taken great pride in manufacturing high-quality construction machinery that is capable of working on demanding job sites and coping with difficult working conditions. With the new ZAXIS medium excavator range, we have endeavoured to extend our industry-leading expertise and further develop our advanced technology, so that customers around the world can continue to rely on our extremely durable machines.



# Build to conquer tough working environments

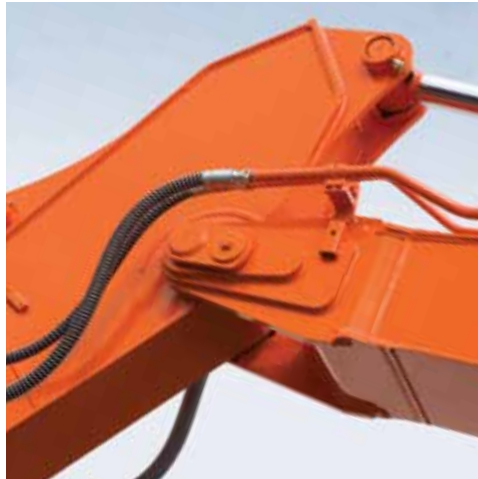

## Durable parts

The new ZAXIS 190 has been designed to operate in the most challenging of working conditions. Tough job sites require reliable machines, which deliver increased levels of availability and productivity. The bottom line is that you will enjoy a lower cost of ownership thanks to the durability of our medium excavators.

The strengthened boom end and foot on each new ZAXIS 190 are good examples. The brackets on the boom end and foot have been equipped with bushings to enhance their durable characteristics and withstand the rigours of long hours in rugged environments.

A filter-type high-performance water separator is provided standard. It captures moisture in fuel, even from fuel which contains a large amount of moisture.

## Reinforced undercarriage

The front idler and adjuster cylinder have been reinforced on the ZAXIS 190 for added durability. In addition, mud no longer sticks to the adjuster cylinder.

Reliability has been further addressed with increase in the welded section parts that comprise the X-beam. The travel motor brackets' upper and lower plates have been extended, which has delivered a 40% reduction in stress.

## ROPS-compliant cab

The pressurised and ROPS-compliant CRES V (Center pillar reinforced structure) cab prevents the penetration of dust and protects you from the potential risks of the job site. The Roll-over Protective Structure (ROPS) is designed to protect the operator in the unlikely event of the machine tipping or rolling over.

## Key features

- Proven Hitachi quality
- More than 40 years of expertise
- Strengthened front attachment
- Reinforced undercarriage



# MAINTENANCE

Like all new Hitachi medium excavators, the ZAXIS 190 has a series of easily accessible features for routine cleaning and maintenance. Our aim was to build upon our reputation for reliable, high-quality machines, which deliver impressive levels of productivity and availability. Ultimately, these quick and convenient solutions will give you even greater confidence in your investment, and more time to focus on the task at hand.



# Keep working for longer thanks to user-friendly accessible features



## Easy access

We have made life easier for you by introducing a range of convenient features integrated within the new ZAXIS range of medium excavators. Our engineers have assessed your requirements and integrated a number of time-saving factors for routine maintenance.

Using the technology within the multi-function LCD monitor you can check engine oil volumes and see the warning light that appears when the hydraulic oil and fuel filters are due for replacement. In addition, you can set the routine service schedule to help prevent breakdowns each time the ignition switch is turned on.

On the exterior of the ZAXIS 190, the air conditioning condenser can be easily opened for cleaning the condenser and radiator. Severe blockages can also be cleared by blowing air through the convenient one-touch openable upper cover above the radiator.

From ground level, you can replace the fuel filters, engine oil filter and air cleaner, and other work is aided by non-slip steps for easy access to the upper structure of the machine.

## Easy cleaning

We believe that easy routine maintenance enhances the levels of productivity and availability for your machine. That's why we have designed the ZAXIS 190 with a series of convenient and quick solutions, so that you can enjoy long, trouble-free days on the job site.

The interior anti-dust filter is a good example of these initiatives. It has been placed on the outside of the air conditioning condenser and fuel cooler, and away from the fan so that dust and particles can be caught evenly without them collecting in one place.

The cooling package has been placed in parallel and the slanted side frame also aids the cleaning process.

## Key features

- Global e-Service monitors muffler filter
- Daily checks from ground level
- Oil volumes checked from the operator's seat
- Quick and easy service access



# SUPPORT CHAIN

As soon as you become a Hitachi customer, you can rely on first-class after-sales service from your authorised dealer. Hitachi provides extensive support to each of the dealers within the European network, so that they can ensure your ZAXIS 190 continues to meet your requirements and exceed expectations. To further protect your investment in Hitachi construction machinery, we have introduced the Hitachi Support Chain after-sales programme. This gives you the flexibility to create a tailor-made service plan from the the following key-areas, "links" in the chain of service available from Hitachi via your local dealer.



# A flexible after-sales programme created to protect your investment

## Global e-Service

The new ZAXIS excavator is equipped with a GPRS communication system\*. This sends a wide range of machine data to the Hitachi main server. Via the Global e-Service database, you will have remote access to all of this data. All you need is an internet connection and your Global e-Service log-in details.

Global e-Service enables you and your dealer to download and share this data, helping you to remotely manage your fleet. The online facility also helps your dealer to proactively advise you on preventive maintenance and related special offers.

The latest information on the ZAXIS excavator is available 24/7 and includes operational data, such as the number of working hours, fuel consumption figures, working modes and location. This helps you to reduce running costs, plan jobs efficiently and keep up to date with machine maintenance – to ensure optimum performance and minimal downtime.

## Technical support

The professional and highly trained Hitachi service team combines the global expertise and knowledge of Hitachi Construction Machinery with your local language and culture. We take a proactive approach towards customer service by continuously training our dealer personnel, so that the available global knowledge is passed on to each individual technician in our dealer network.

## Extended warranty and service contracts

Every new Hitachi model is covered by a full manufacturer's warranty. However, your ZAXIS excavator may require extra protection due to severe working conditions or to minimise equipment repair costs. To meet these demands, our dealers offer the option of a unique extended warranty programme (HELP – Hitachi Extended Life Program) and comprehensive service contracts – the most effective way to optimise the performance of your new ZAXIS excavator.

## Parts and Remanufactured Components

Hitachi offers different lines of parts and components to suit your specific needs. In addition to our range of genuine parts, there are other options available:

- If your machines have been working for several years, Hitachi can offer a second line of genuine parts as an attractively priced solution.
- For that highly demanding application or climate, Hitachi provides a line of parts with extra performance.
- When you are looking for an economical solution for preventive replacements, remanufactured components are the best option.

Whatever choice you make, you can be assured of the renowned Hitachi quality and warranty to give you added peace of mind.

Your Hitachi dealer can supply you with more details on each of the above parts lines.



\* The GPRS communication system is standard equipment for new ZAXIS excavators, however, the availability of the communication system depends on licensing regulations in your country. Please contact your Hitachi dealer for more information or to apply for a Global e-Service account.

## Key features

- Check each of your machines from your office – 24/7
- Have a remote insight into fuel consumption
- Check the current and previous locations and movements of your machine(s)
- See maintenance status and items due for renewal on each of your machines
- Receive e-mail notifications for any machine alerts, unexpected movements and so on

# SPECIFICATIONS

## ENGINE

Model .....	Isuzu AM-4HK1X
Type .....	4-cycle water-cooled, common rail direct injection
Aspiration .....	Variable geometry turbocharged, intercooled, cooled EGR
Aftertreatment .....	Muffler filter
No. of cylinders .....	4
Rated power	
ISO 9249, net .....	122 kW (164 HP) at 2 000 min <sup>-1</sup> (rpm)
EEC 80/1269, net .....	122 kW (164 HP) at 2 000 min <sup>-1</sup> (rpm)
SAE J1349, net .....	122 kW (164 HP) at 2 000 min <sup>-1</sup> (rpm)
Maximum torque .....	652 Nm (66.5 kgfm) at 1 500 min <sup>-1</sup> (rpm)
Piston displacement .....	5.193 L
Bore and stroke .....	115 mm x 125 mm
Batteries .....	2 x 12 V / 126 Ah

## HYDRAULIC SYSTEM

### Hydraulic pumps

Main pumps .....	3 variable displacement axial piston pumps
Maximum oil flow .....	2 x 212 L/min 1 x 189 L/min
Pilot pump .....	1 gear pump
Maximum oil flow .....	33.6 L/min

### Hydraulic Motors

Travel .....	2 variable displacement axial piston motors
Swing .....	1 axial piston motor

### Relief Valve Settings

Implement circuit .....	34.3 MPa (350 kgf/cm <sup>2</sup> )
Swing circuit .....	24.9 MPa (254 kgf/cm <sup>2</sup> )
Travel circuit .....	35.5 MPa (362 kgf/cm <sup>2</sup> )
Pilot circuit .....	3.9 MPa (40 kgf/cm <sup>2</sup> )
Power boost .....	38.0 MPa (388 kgf/cm <sup>2</sup> )

### Hydraulic Cylinders

	Quantity	Bore	Rod diameter
Boom	2	120 mm	85 mm
Arm	1	125 mm	90 mm
Bucket	1	105 mm	75 mm
Positioning *	1	150 mm	100 mm

\* For 2-piece boom

## UPPERSTRUCTURE

### Revolving Frame

D-section frame for resistance to deformation.

### Swing Device

Axial piston motor with planetary reduction gear is bathed in oil. Swing circle is single-row. Swing parking brake is spring-set/hydraulic-released disc type.

Swing speed .....	11.8 min <sup>-1</sup> (rpm)
Swing torque .....	53 kNm (5 400 kgfm)

### Operator's Cab

Independent spacious cab, 1 005 mm wide by 1 675 mm high, conforming to ISO\* Standards.

\* International Organization for Standardization

## UNDERCARRIAGE

### Tracks

Heat-treated connecting pins with dirt seals. Hydraulic (grease) track adjusters with shock-absorbing recoil springs.

### Numbers of Rollers and Shoes on Each Side

Upper rollers .....	2
Lower rollers .....	7
Track shoes .....	46
Track guard .....	1

### Travel Device

Each track driven by 2-speed axial piston motor. Parking brake is spring-set/hydraulic-released disc type. Automatic transmission system: High-Low.

Travel speeds .....	High : 0 to 5.5 km/h Low : 0 to 3.5 km/h
---------------------	---

Maximum traction force ... 203 kN (20 700 kgf)

Gradeability .....

70% (35 degree) continuous
----------------------------

## SOUND LEVEL

Sound level in cab according to ISO 6396 .....	LpA 69 dB(A)
External sound level according to ISO 6395 and EU Directive 2000/14/EC .....	LwA 101 dB(A)

## SERVICE REFILL CAPACITIES

Fuel tank .....	330.0 L
Engine coolant .....	25.0 L
Engine oil .....	23.0 L
Swing device .....	6.2 L
Travel device (each side) .....	6.8 L
Hydraulic system .....	220.0 L
Hydraulic oil tank .....	170.0 L



## WEIGHTS AND GROUND PRESSURE

### Operating Weight and Ground Pressure

			ZAXIS 190LC				ZAXIS 190LCN			
Boom type			Monoblock		2-Piece		Monoblock		2-Piece	
Shoe type	Shoe width	Arm length	kg	kPa (kgf/cm <sup>2</sup> )	kg	kPa (kgf/cm <sup>2</sup> )	kg	kPa (kgf/cm <sup>2</sup> )	kg	kPa (kgf/cm <sup>2</sup> )
Triple grouser	500 mm	2.26 m	-	-	-	-	18 700	50 (0.51)	19 600	53 (0.54)
		2.71 m	-	-	-	-	18 800	51 (0.52)	19 700	53 (0.54)
	600 mm	2.26 m	19 000	42 (0.43)	19 800	44 (0.45)	18 900	42 (0.43)	19 800	44 (0.45)
		2.71 m	19 100	43 (0.44)	19 900	44 (0.45)	19 000	42 (0.43)	19 900	44 (0.45)
	700 mm	2.26 m	19 400	37 (0.38)	20 200	39 (0.40)	-	-	-	-
		2.71 m	19 500	37 (0.38)	20 300	39 (0.40)	-	-	-	-
	800 mm	2.26 m	19 600	33 (0.34)	20 500	34 (0.35)	-	-	-	-
		2.71 m	19 700	33 (0.34)	20 600	34 (0.35)	-	-	-	-

Including 0.70 m<sup>3</sup> (ISO heaped), bucket weight (600 kg) and counterweight (3 700 kg).

### Basic Machine Weight and Overall Width

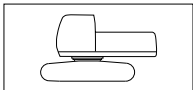

Excluding front end attachment, fuel, hydraulic oil and coolant etc. Including counterweight.

#### ZAXIS 190LC

Shoe width	Weight	Overall width
600 mm	15 100 kg	2 800 mm
700 mm	15 500 kg	2 900 mm
800 mm	15 700 kg	3 000 mm

#### ZAXIS 190LCN

Shoe width	Weight	Overall width
500 mm	14 800 kg	2 500 mm
600 mm	15 000 kg	2 580 mm

### Components Weight

	Weight
Counterweight	3 700 kg
Monoblock boom (with arm cylinder and boom cylinder)	2 030 kg
2-Piece boom (with arm cylinder and boom cylinder)	2 840 kg
2.26 m arm (with bucket cylinder)	820 kg
2.71 m arm (with bucket cylinder)	890 kg
0.70 m <sup>3</sup> bucket	600 kg

## BUCKET AND ARM DIGGING FORCE

Arm length	ZAXIS 190LC / ZAXIS 190LCN	
	2.26 m	2.71 m
Bucket digging force* ISO	127 kN (13 000 kgf)	
Bucket digging force* SAE : PCSA	112 kN (11 400 kgf)	
Arm crowd force* ISO	108 kN (11 100 kgf)	95 kN (9 700 kgf)
Arm crowd force* SAE : PCSA	104 kN (10 600 kgf)	91 kN (9 300 kgf)

\* At power boost

# SPECIFICATIONS

## WORKING RANGES

### MONOBLOCK BOOM

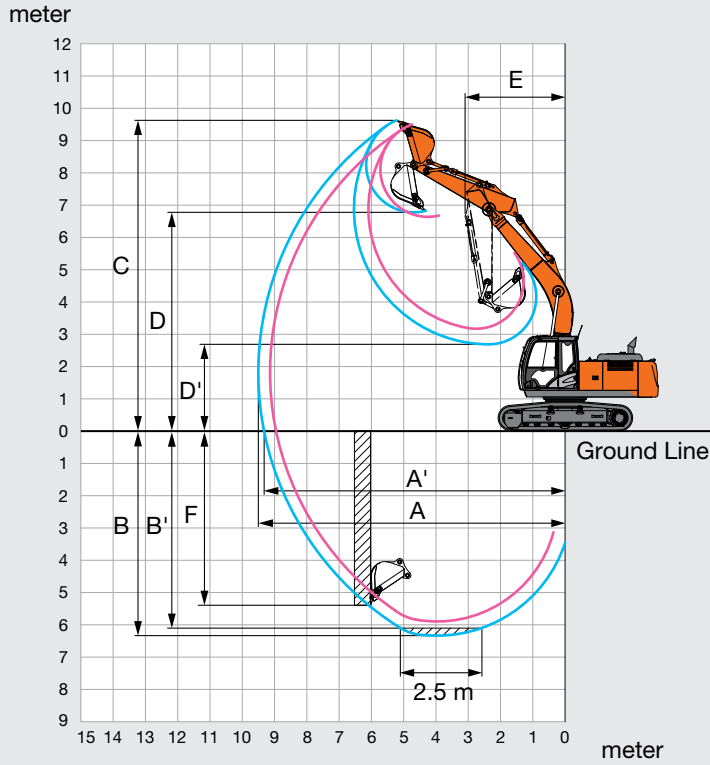

### 2-PIECE BOOM

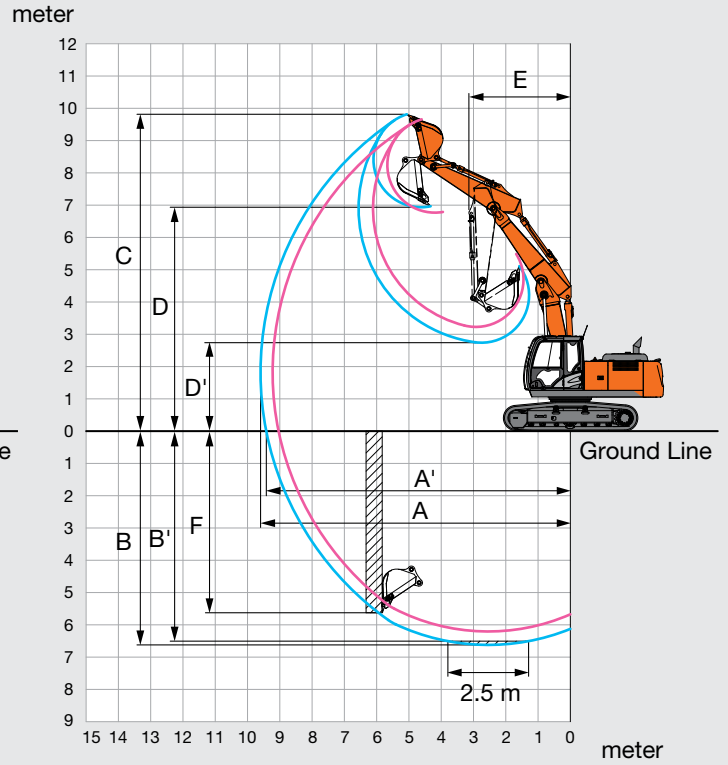

Unit: mm

	ZAXIS 190LC / ZAXIS 190LCN			
	Monoblock boom		2-Piece boom	
Arm length	2.26 m	2.71 m	2.26 m	2.71 m
A Max. digging reach	9 140	9 500	9 220	9 600
A' Max. digging reach (on ground)	8 950	9 320	9 040	9 420
B Max. digging depth	5 900	6 340	6 210	6 620
B' Max. digging depth (2.5 m level)	5 650	6 100	6 080	6 510
C Max. cutting height	9 510	9 630	9 660	9 810
D Max. dumping height	6 640	6 770	6 770	6 930
D' Min. dumping height	3 170	2 690	3 230	2 740
E Min. swing radius	3 110	3 100	3 270	3 140
F Max. vertical wall digging depth	5 110	5 400	5 220	5 630

Excluding track shoe lug

## DIMENSIONS

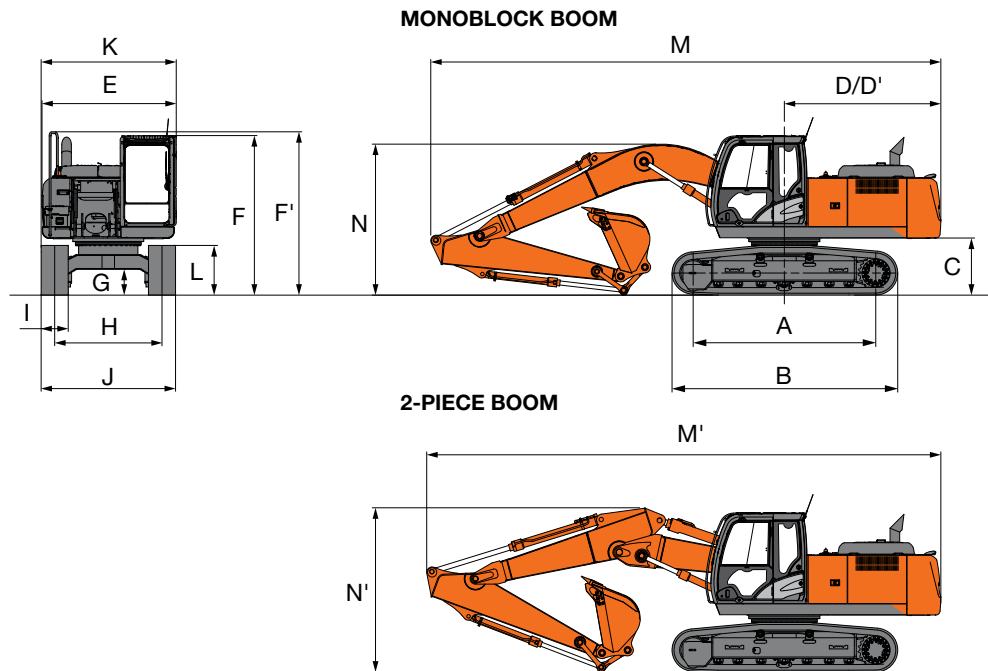

Unit: mm

	ZAXIS 190LC	ZAXIS 190LCN
A Distance between tumblers	3 370	3 370
B Undercarriage length	4 170	4 170
* C Counterweight clearance	1 030	1 030
D Rear-end swing radius	2 890	2 890
D' Rear-end length	2 890	2 890
E Overall width of upperstructure	2 480	2 480
F Overall height of cab	2 950	2 950
F' Over height of upperstructure	3 010	3 010
* G Min. ground clearance	450	450
H Track gauge	2 200	1 990
I Track shoe width	G 600	G 500
J Undercarriage width	2 800	2 480
K Overall width	2 800	2 500
L Track height with triple grouser shoes	890	890
<b>MONOBLOCK BOOM</b>		
M Overall length		
With 2.26 m arm	9 470	9 470
With 2.71 m arm	9 420	9 420
* N Overall height of boom		
With 2.26 m arm	2 940	2 940
With 2.71 m arm	2 750	2 750
<b>2-PIECE BOOM</b>		
M' Overall length		
With 2.26 m arm	9 500	9 500
With 2.71 m arm	9 490	9 490
* N' Overall height of boom		
With 2.26 m arm	3 010	3 010
With 2.71 m arm	3 030	3 030

\* Excluding track shoe lug      G: Triple grouser shoe

# LIFTING CAPACITIES

- Notes: 1. Ratings are based on ISO 10567.  
 2. Lifting capacity does not exceed 75% of tipping load with the machine on firm, level ground or 87% full hydraulic capacity.  
 3. The load point is the center-line of the bucket pivot mounting pin on the arm.  
 4. \*Indicates load limited by hydraulic capacity.  
 5. 0 m = Ground.

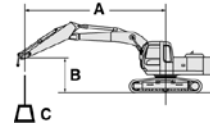

A: Load radius  
 B: Load point height  
 C: Lifting capacity

For lifting capacities, subtract bucket and quick hitch weight from lifting capacities.

## ZAXIS 190LC MONOBLOCK BOOM

Rating over-front Rating over-side or 360 degrees Unit : kg

Conditions	Load point height m	Load radius										At max. reach		
		1.5 m		3.0 m		4.5 m		6.0 m		7.5 m		meter		
Boom 5.68 m Arm 2.26 m Counterweight 3 700 kg Shoe 600 mm	6.0					*6 350	*6 350	*5 710	4 530			*4 470	4 070	6.40
	4.5			*10 380	*10 380	*7 600	6 820	*6 530	4 430			*4 390	3 350	7.17
	3.0					*9 470	6 370	6 430	4 240	4 580	3 060	4 510	3 010	7.58
	1.5					9 650	5 990	6 230	4 070	4 500	2 990	4 370	2 900	7.66
	0 (Ground)					9 460	5 830	6 100	3 950			4 500	2 980	7.44
	-1.5			*9 030	*9 030	9 440	5 810	6 070	3 930			5 010	3 290	6.89
-3.0			*13 240	11 190	9 560	5 920						6 320	4 100	5.91
Boom 5.68 m Arm 2.71 m Counterweight 3 700 kg Shoe 600 mm	6.0							*4 910	4 590			*3 400	*3 400	6.83
	4.5					*6 930	*6 930	*6 080	4 470	*3 620	3 140	*3 370	3 100	7.56
	3.0					*8 840	6 460	6 460	4 270	4 590	3 070	*3 490	2 810	7.94
	1.5					9 710	6 040	6 240	4 070	4 490	2 980	*3 780	2 700	8.02
	0 (Ground)			*4 770	*4 770	9 450	5 810	6 090	3 930	4 420	2 910	4 180	2 760	7.82
	-1.5	*5 340	*5 340	*8 800	*8 800	9 380	5 760	6 030	3 880			4 590	3 010	7.29
-3.0	*9 510	*9 510	*14 360	11 020	9 460	5 820	6 080	3 930			5 590	3 640	6.38	
-4.5			*10 670	*10 670	*7 540	6 050						*6 840	5 480	4.84

## ZAXIS 190LCN MONOBLOCK BOOM

Rating over-front Rating over-side or 360 degrees Unit : kg

Conditions	Load point height m	Load radius										At max. reach		
		1.5 m		3.0 m		4.5 m		6.0 m		7.5 m		meter		
Boom 5.68 m Arm 2.26 m Counterweight 3 700 kg Shoe 500 mm	6.0					*6 350	*6 350	*5 710	4 070			*4 470	3 660	6.40
	4.5			*10 380	*10 380	*7 600	6 100	*6 530	3 970			*4 390	3 000	7.17
	3.0					*9 470	5 660	6 340	3 800	4 520	2 740	4 450	2 700	7.58
	1.5					9 520	5 300	6 140	3 620	4 440	2 670	4 310	2 590	7.66
	0 (Ground)					9 330	5 140	6 020	3 510			4 440	2 650	7.44
	-1.5			*9 030	*9 030	9 310	5 120	5 990	3 490			4 940	2 930	6.89
-3.0			*13 240	9 660	9 430	5 220						6 230	3 650	5.91
Boom 5.68 m Arm 2.71 m Counterweight 3 700 kg Shoe 500 mm	6.0							*4 910	4 130			*3 400	3 330	6.83
	4.5					*6 930	6 200	*6 080	4 010	*3 620	2 820	*3 370	2 780	7.56
	3.0					*8 840	5 750	6 380	3 820	4 530	2 740	*3 490	2 510	7.94
	1.5					9 580	5 340	6 160	3 630	4 430	2 660	*3 780	2 410	8.02
	0 (Ground)			*4 770	*4 770	9 320	5 120	6 000	3 490	4 360	2 590	4 120	2 450	7.82
	-1.5	*5 340	*5 340	*8 800	*8 800	9 250	5 060	5 940	3 440			4 520	2 680	7.29
-3.0	*9 510	*9 510	*14 360	9 490	9 330	5 130	6 000	3 490			5 510	3 240	6.38	
-4.5			*10 670	9 840	*7 540	5 350						*6 840	4 860	4.84

# LIFTING CAPACITIES

- Notes: 1. Ratings are based on ISO 10567.  
 2. Lifting capacity does not exceed 75% of tipping load with the machine on firm, level ground or 87% full hydraulic capacity.  
 3. The load point is the center-line of the bucket pivot mounting pin on the arm.  
 4. \*Indicates load limited by hydraulic capacity.  
 5. 0 m = Ground.

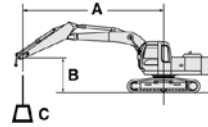

A: Load radius  
 B: Load point height  
 C: Lifting capacity

For lifting capacities, subtract bucket and quick hitch weight from lifting capacities.

## ZAXIS 190LC 2-PIECE BOOM

Rating over-front Rating over-side or 360 degrees Unit : kg

Conditions	Load point height m	Load radius										At max. reach		
		1.5 m		3.0 m		4.5 m		6.0 m		7.5 m				meter
2-Piece Boom Arm 2.26 m Counterweight 3 700 kg Shoe 600 mm	9.0											*6 880	*6 880	2.59
	7.5					*6 120	*6 120					*4 860	*4 860	5.19
	6.0			*6 040	*6 040	*6 380	*6 380	*5 270	4 570			*4 380	3 920	6.49
	4.5			*11 420	*11 420	*7 210	7 020	*5 530	4 600			*4 260	3 210	7.26
	3.0	*13 500	*13 500	*14 130	12 630	*9 250	*6 840	*6 120	4 490	4 560	3 000	*4 170	2 880	7.66
	1.5			*15 520	12 270	10 020	6 890	6 400	4 280	4 480	2 920	4 250	2 770	7.74
	0 (Ground)	*13 040	*13 040	*17 340	11 900	10 250	6 410	6 280	4 050	4 400	2 850	4 380	2 840	7.53
	-1.5	*17 780	*17 780	*17 800	11 390	9 750	5 980	6 090	3 880			4 870	3 140	6.98
	-3.0	*19 510	*19 510	*16 200	11 130	9 580	5 840					*4 910	3 960	5.96
-4.5														
2-Piece Boom Arm 2.71 m Counterweight 3 700 kg Shoe 600 mm	9.0			*5 460	*5 460							*4 590	*4 590	3.59
	7.5					*5 030	*5 030					*3 610	*3 610	5.74
	6.0					*5 310	*5 310	*4 840	4 640			*3 310	*3 310	6.94
	4.5			*7 930	*7 930	*6 690	*6 690	*5 220	4 670	*3 910	3 100	*3 250	2 970	7.66
	3.0	*13 560	*13 560	*14 510	12 690	*8 420	6 870	*5 790	4 550	*4 540	3 060	*3 340	2 680	8.04
	1.5	*13 020	*13 020	*15 190	12 320	10 010	7 030	6 380	4 370	4 510	2 960	*3 580	2 570	8.12
	0 (Ground)	*12 470	*12 470	*16 870	12 130	9 900	6 500	6 300	4 100	4 400	2 850	*4 020	2 620	7.91
	-1.5	*15 370	*15 370	*17 620	11 440	9 820	6 040	6 100	3 880			4 450	2 860	7.40
	-3.0	*16 090	*16 090	*17 150	11 080	9 530	5 790	6 040	3 830			*4 820	3 460	6.49
-4.5			*10 600	*10 600							*9 910	*9 910	3.19	

## ZAXIS 190LCN 2-PIECE BOOM

Rating over-front Rating over-side or 360 degrees Unit : kg

Conditions	Load point height m	Load radius										At max. reach		
		1.5 m		3.0 m		4.5 m		6.0 m		7.5 m				meter
2-Piece Boom Arm 2.26 m Counterweight 3 700 kg Shoe 500 mm	9.0											*6 880	*6 880	2.59
	7.5					*6 120	*6 120					*4 860	*4 860	5.19
	6.0			*6 040	*6 040	*6 380	*6 380	*5 270	4 100			*4 380	3 510	6.49
	4.5			*11 420	*11 420	*7 210	6 430	*5 530	4 140			*4 260	2 860	7.26
	3.0	*13 500	*13 500	*14 130	11 170	*9 250	6 200	*6 120	4 030	4 500	2 660	*4 170	2 560	7.66
	1.5			*15 520	*11 310	9 910	6 140	*6 330	3 820	4 410	2 590	4 190	2 450	7.74
	0 (Ground)	*13 040	*13 040	*17 340	10 290	10 120	5 680	6 190	3 590	4 340	2 520	4 320	2 510	7.53
	-1.5	*17 780	*17 780	*17 800	9 810	9 620	5 270	6 010	3 430			4 800	2 780	6.98
	-3.0	*19 510	*19 510	*16 200	9 560	9 450	5 130					*4 910	3 500	5.96
-4.5														
2-Piece Boom Arm 2.71 m Counterweight 3 700 kg Shoe 500 mm	9.0			*5 460	*5 460							*4 590	*4 590	3.59
	7.5					*5 030	*5 030					*3 610	*3 610	5.74
	6.0					*5 310	*5 310	*4 840	4 220			*3 310	3 180	6.94
	4.5			*7 930	*7 930	*6 690	*6 430	*5 220	4 120	*3 910	2 760	*3 250	2 640	7.66
	3.0	*13 560	*13 560	*14 510	11 250	*8 420	6 240	*5 790	3 910	4 540	2 720	*3 340	2 370	8.04
	1.5	*13 020	*13 020	*15 190	10 840	9 900	6 280	6 310	3 640	4 450	2 620	*3 580	2 270	8.12
	0 (Ground)	*12 470	*12 470	*16 870	10 500	9 780	5 770	6 220	3 430	4 340	2 520	3 990	2 310	7.91
	-1.5	*15 370	*15 370	*17 620	9 860	9 690	5 320	6 020	3 380			4 380	2 530	7.40
	-3.0	*16 090	*16 090	*17 150	9 520	9 400	5 080	5 950				*4 820	3 060	6.49
-4.5			*10 600	9 610							*9 910	8 720	3.19	

# EQUIPMENT

● ..... Standard equipment

○ ..... Optional equipment

## ENGINE

Air cleaner double filters	●
Auto idle system	●
Auto shut-down control	●
Cartridge-type engine oil filter	●
Cartridge-type fuel pre-filter	●
Cartridge-type fuel main filter	●
Dust-proof indoor net	●
Dry-type air filter with evacuator valve (with air filter restriction indicator)	●
Electrical fuel feed pump	●
ECO/PWR mode control	●
Engine oil drain coupler	●
Engine warm-up device	●
Fan guard	●
Fuel cooler	●
Cold fuel resistance valve	○
High performance water separator	●
Isolation-mounted engine	●
Muffler filter	●
Pre-cleaner	○
Radiator, oil cooler and intercooler	●
Radiator reserve tank	●
50 A alternator	●

## HYDRAULIC SYSTEM

Auto power lift	●
Control valve with main relief valve	●
Full-flow filter	●
High mesh full flow filter with restriction indicator	○
Hose rupture valve for boom	●
Hose rupture valve for arm	○
Pilot filter	●
Power boost	●
Suction filter	●
Swing dampener valve	●
Two extra port for control valve	●
Variable reliefvalve for breaker & crusher	●
Work mode selector	●

## CAB

Auxiliary function lever (Breaker assist)	○
All-weather sound suppressed steel cab	●
AM-FM radio	●
Ashtray	●
Auto control air conditioner	●
AUX. terminal and storage	●
CRES V (Center pillar reinforced structure) cab	●
Drink holder with hot & cool function	●
Electric double horn	●
Engine shut-off switch	●
Equipped with reinforced, tinted (green color) glass windows	●
Evacuation hammer	●
Floor mat	●
Footrest	●
Front window washer	●
Windows on front, upper, lower and left side can be opened	●
Glove compartment	●
Hot & cool box	●
Intermittent windshield wipers	●
Key cylinder light	●
Laminated round glass window	○
LED room light with door courtesy	●
OPG front guard Level II (ISO10262) compliant cab	○
OPG top guard fitted Level II (ISO10262) compliant cab	○
Pilot control shut-off lever	●
Rain guard	○
Rear tray	●
Retractable seat belt	●
ROPS (ISO12117-2) compliant cab	●
Rubber radio antenna	●
Seat : air suspension seat with heater	●
Seat adjustment part : backrest, armrest, height and angle, slide forward / back	●
Short wrist control levers	●
Sun visor (front window/side window)	○
Transparent roof with slide curtain	●
2 speaker	●
4 fluid-filled elastic mounts	●
12 V power outlet	○
24 V cigarette lighter	●

## MONITOR SYSTEM

Alarm buzzers: overheat, engine oil pressure, overload	●
Alarms: overheat, engine warning, engine oil pressure, alternator, minimum fuel level, hydraulic filter restriction, air filter restriction, work mode, overload, etc	●
Display of meters: water temperature, hour, fuel rate, clock	●
Other displays: work mode, auto-idle, glow, rearview monitor, operating conditions, etc	●
32 languages selection	●

## LIGHTS

Additional cab roof front lights	○
Additional cab roof rear lights	○
Additional boom light with cover	○
Rotating lamp	○
2 working lights	●

## UPPER STRUCTURE

Electric fuel refilling pump with auto stop and filter	●
Fuel level float	●
Hydraulic oil level gauge	●
Rear view camera	●
Rear view mirror (right & left side)	●
Swing parking brake	●
Tool box	●
Undercover	●
Utility space	●
3 700 kg counterweight	●
2 x 126 Ah batteries	●

## UNDERCARRIAGE

Bolt-on sprocket	●
Reinforced track links with pin seals	●
Travel motor covers	●
Travel parking brake	●
Track undercover	○
Upper and lower rollers	●
1 track guards (each side) and hydraulic track adjuster	●
2 track guards (each side) and hydraulic track adjuster	○
4 tie down hooks	●
600 mm triple grouser shoes : ZAXIS 190LC	●
500 mm triple grouser shoes : ZAXIS 190LCN	●

## FRONT ATTACHMENTS

Casted bucket link A	●
Centralized lubrication system	●
Dirt seal on all bucket pins	●
Flanged pin	●
HN bushing	●
Reinforced resin thrust plate	●
WC (tungsten-carbide) thermal spraying	●
Welded bucket link A with welded hook	○

## ATTACHMENTS

Accessories for 2 speed selector	○
Additional pump (30 L/min)	○
Assist piping	○
Attachment basic piping	●
Breaker and crusher piping	●
HSB Parts for breaker and crusher	●
Pilot accumulator	○

## MISCELLANEOUS

Global e-Service	●
Lockable fuel refilling cap	●
Lockable machine covers	●
Onboard information controller	●
Skid-resistant, plates and handrails	●
Standard tool kit	●
Travel direction mark on track frame	●
Theft prevention system*	○

Standard and optional equipment may vary by country, so please consult your Hitachi dealer for details.

\* Hitachi Construction Machinery cannot be held liable for theft, any system will just minimize the risk of theft.





**Built on the foundation of superb technological capabilities, Hitachi Construction Machinery is committed to providing leading-edge solutions and services to contribute as a reliable partner to the business of customers worldwide.**

---

## Hitachi Environmental Vision 2025

---

The Hitachi Group released the Environmental Vision 2025 to curb annual carbon dioxide emissions. The Group is committed to global production while reducing environmental impact in life cycles of all products, and realizing a sustainable society by tackling three goals — prevention of global warming, recycling of resources, and enhancement of ecosystem.

### **Reducing Environmental Impact by New ZAXIS**

Hitachi makes a green way to cut carbon emissions for global warming prevention according to LCA\*. New ZAXIS utilizes lots of technological advances, including the new ECO mode, and Isochronous Control. Hitachi has long been committed to recycling of components, such as aluminum parts in radiators and oil cooler. Resin parts are marked for recycling.

\*Life Cycle Assessment – ISO 14040

Prior to operating this machine, including satellite communication system, in a country other than a country of its intended use, it may be necessary to make modifications to it so that it complies with the local regulatory standards (including safety standards) and legal requirements of that particular country. Please do not export or operate this machine outside the country of its intended use until such compliance has been confirmed. Please contact your Hitachi dealer in case of questions about compliance.

These specifications are subject to change without notice.

Illustrations and photos show the standard models, and may or may not include optional equipment, accessories, and all standard equipment with some differences in color and features. Before use, read and understand the Operator's Manual for proper operation.



KS-EN265EU